

A diamond anvil cell with resistive heating for high pressure and high temperature x-ray diffraction and absorption studies

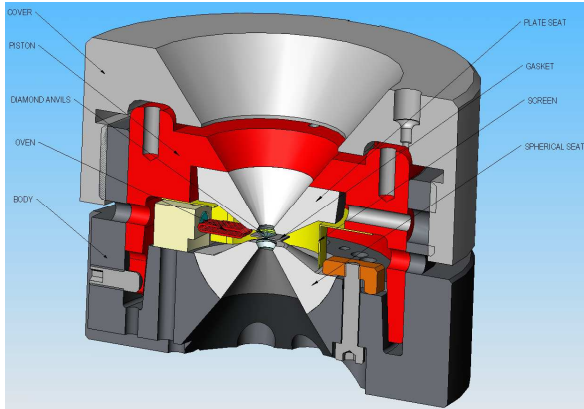

Sebastien Pasternak¹, Giuliana Aquilanti¹, Sakura Pascarelli¹, Roberta Poloni^{1,2}, Bernard Canny³, Marie-Vanessa Coulet⁴, and Lin Zhang¹.
 1 European Synchrotron Radiation Facility, 6 rue Jules Horowitz, 38043 Grenoble, Cedex, France
 2 Institut de Ciència de Materials de Barcelona (CSIC), Campus de la UAB, E-08193 Bellaterra, Barcelona Spain
 3 IMPMC-CNRS UMR, 7590 Université Paris VI, 140 rue de Lourmel, 75015 Paris, France
 4 IM2NP-UMR CNRS, 6242 Université Paul Cezanne Campus de St Jérôme, 13397 Marseille Cedex 20, France

In this poster we describe a prototype of a diamond anvil cell DAC for high pressure/high temperature studies. This DAC combines the use of an original resistive oven of 250 W power in a very small volume, associated with special conical seats for Boehler-type diamond anvils in order to have a large angular acceptance. To protect the diamond anvils from burning and to avoid the oven oxidation, the heated DAC is enclosed in a vacuum chamber. The assemblage was used to study the melting curve of germanium at high pressure up to 20 GPa and high temperature up to 1200 K using x-ray diffraction and x-ray absorption spectroscopy.



HP HT DAC

The DAC is capable of covering a T range up to 1200 K and a pressure up to 100 GPa (depending on the size of diamonds used) with a large opening angle of 70°. This temperature range allows the investigation of the structure of the liquid phases of most of group IV, III-V, and IV-V semiconductors. For these first tests devoted to assess the correct operation of the high pressure device under high temperature conditions, the maximum pressure was limited to 20 GPa, sufficient for the investigation of the zincblende ZB and Sn phases of solid Ge and of the corresponding liquid phase just above the melting curve.

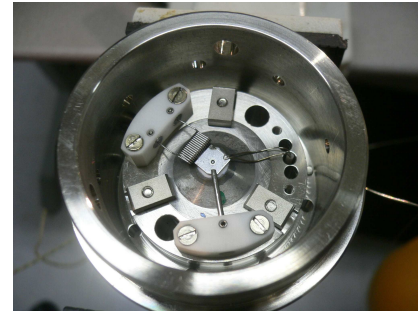

Materials

The body, piston, and lid of the DAC are made of *Nimonic 80A*, a fireproof alloy with good mechanical characteristics at high temperature. The realization of the DAC was done at the ESRF at the TBS mechanics workshop by P. Dideron. The body and the piston are both coated to lubricate and avoid mechanical cell blocking at high temperature. The coating treatment consists in a bombardment of a thin layer of graphite. A rhenium gasket is generally preferred because of excellent mechanical characteristics at high temperature.

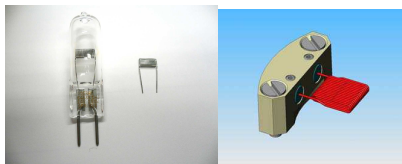

The heating element

Sample temperatures of 1200 K have been obtained using a resistive furnace installed around the diamonds. The heating of the sample is achieved by radiation. The furnace consists in a tungsten coil of halogen light 24 V, 250 W from OSRAM. A special plug of alumina was designed to fix the coil in a restricted space in order to maximize the power while minimizing the diamond-heater distance.

The radiation screen

A radiation screen, placed around the diamonds has been implemented with a double function. On one side, it protects the body of the cell and the piston from radiative heating. On the other, it helps reduce power losses by reflecting radiation back toward the diamonds. The internal surface is mirror polished for this purpose.

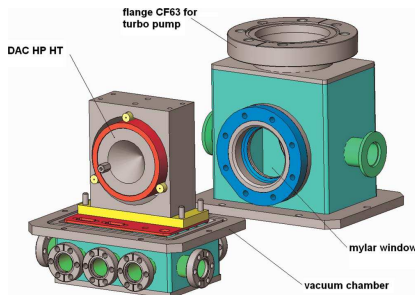
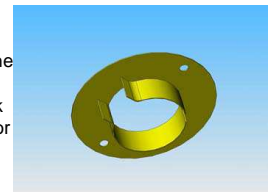

The vacuum chamber

All the equipment is inserted into a stainless steel vacuum chamber. Mylar windows of 150 μm of thickness allow transmission of the x rays. The windows are cooled by an air stream to reduce the thermal radiation damage. It is important to keep the vacuum below 10^{-5} mbar to avoid the burning of the diamonds, and to protect the oven from oxidation. Numerous holes are drilled in the DAC to increase pumping efficiency in the hot region around the diamonds and heater. A turbo pump is directly mounted on the vacuum chamber to maximize the pumping speed.

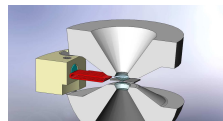
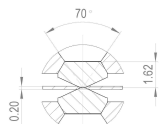

Diamond anvils and settings

The large angular acceptance is obtained using special conical diamond anvils of Boehler from Almax. Specially shaped diamond anvil seats have been developed to receive them and are lapped for a perfect adjustment. The seats are made of special tungsten carbide M20. This micrograin tungsten carbide is used in forging tools for its good mechanical properties at high temperature and pressure. The shape of these seats is designed to host the resistive oven.

Temperature measurement

The sample temperature is monitored using a combination of different independent measurements. A *K*-type thermocouple is fixed on the back side of one of the diamonds and reports the evolution of the diamond temperature, which is directly related to the temperature of the sample through a calibration curve that needs to be established prior to the experiment. An indirect temperature measurement is also performed by tracking XRD profiles of suitable temperature calibrants placed within the sample volume.

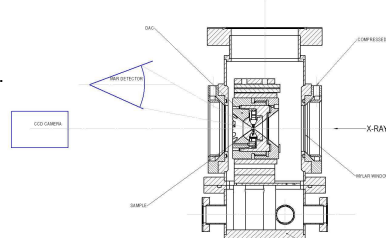

Phase diagram of germanium

Phase diagram of germanium according to black line. The green dots are the thermodynamic states investigated in this study. The dotted line with arrows is representative for the experimentally imposed path in the phase diagram.

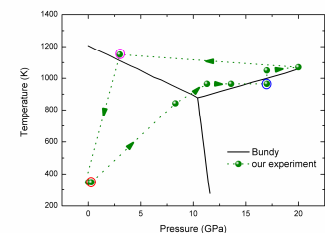

The loading

A fine powder of germanium was enclosed in a rhenium gasket of an initial thickness of 40 μm , drilled with a hole of 150 μm . The sample was isolated from the Re metal using a boron nitride ring in order to prevent the chemical reaction of Ge with Re at high temperature.

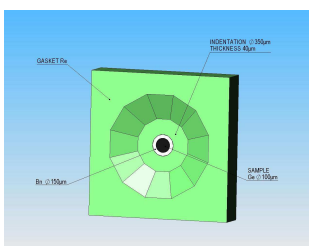

DAC at 1200K

