



XMaS/BM28: The UK Materials Science Beamline at the ESRF!

or

“Everything you always wanted to know about *XMaS**
*But were afraid to ask.”

Didier Wermeille

XMaS/ESRF, Grenoble

o.b.o. the whole XMaS team

EUO webinar, 21 November 2024



XMaS in a nutshell

XMaS is one of [EPSRC's National Research Facilities](#):

“.....world class facilities for the engineering and physical sciences research communities to use. These facilities provide leading edge capabilities and technique development at a national level.”

XMaS has been an integral part of the UK SR infrastructure since 1997, working in partnership with the ESRF and DLS.

XMaS is a joint project funded by the EPSRC and run by the universities of Liverpool and Warwick.

XMaS provides free at the point of access to synchrotron radiation to UK and international users.

It started as *X*-ray *Ma*gnetic *S*cattering. It is now *X*-ray *Ma*terials *S*cience.



A brief history of *XMaS*

- 1990: Bill Stirling & Malcolm Cooper started discussions about the possibility of a UK CRG beamline at the ESRF;
- 1992: Proposal to finance a proper design study: 60 k€;
- 1994: Design and construction of *XMaS*, an X-ray Magnetic Scattering beamline on port D28;
- 1997: Inauguration of *XMaS*, first beam and first users, birth and baptism;
- 1997: 1st grant;
- 2002: 2nd grant;
- 2007: 3rd grant;
- 2012: 4th grant, *XMaS* becomes a UK Mid-Range Facility (MRF);
- 2018: 5th grant, *XMaS* becomes a UK EPSRC National Research Facility (NRF);
- 2024: 6th grant, *XMaS* can capitalise on the ESRF-EBS.

XMaS/BM28 layout

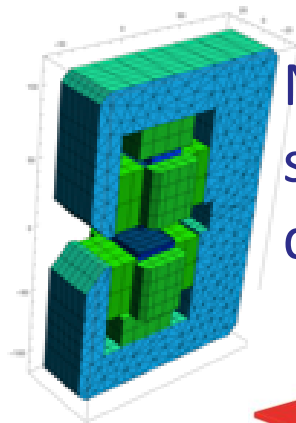

New 0.86 T short-bend dipole

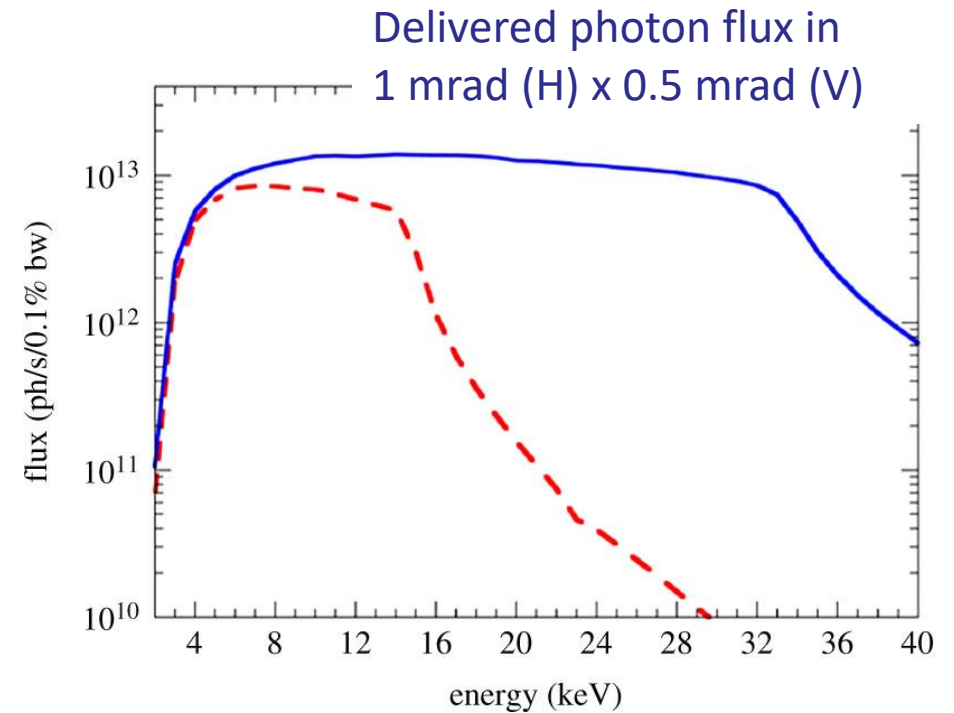
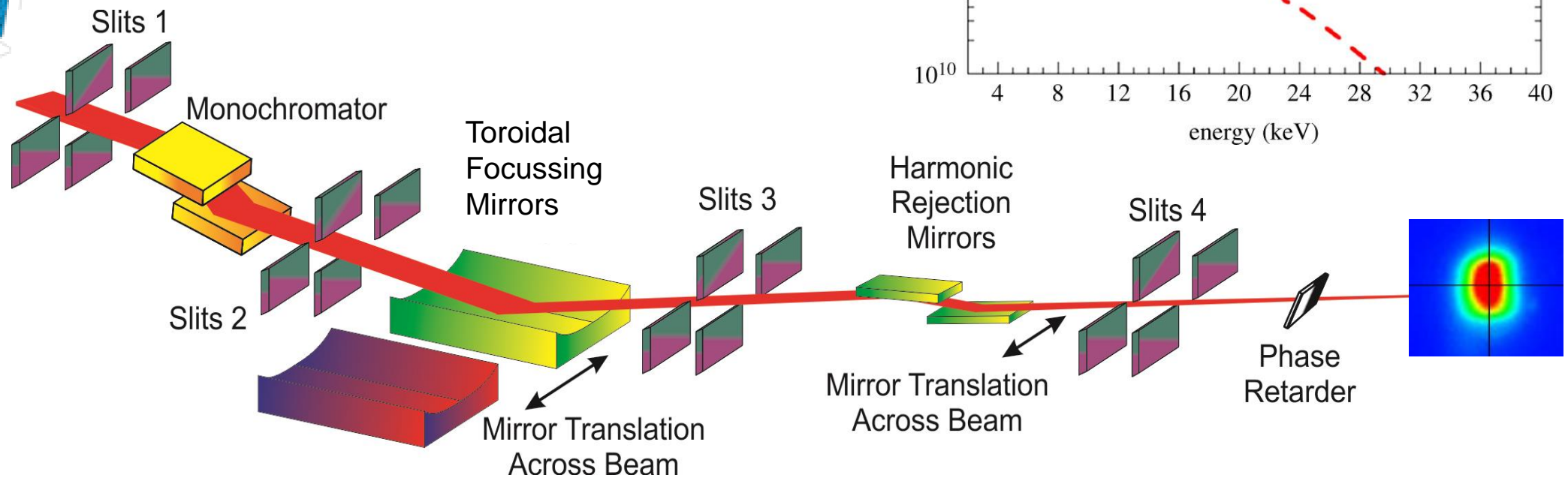

Cryogenically-cooled Si (111) double-crystal monochromator: 2.035 – 47 keV.

Two toroidal mirrors: Pt-coated (up to 47 keV) and Cr-coated (up to 21 keV) Si substrate at 2.5 mrad.

6-circle (4S + 2D) diffractometer with in-vacuum polarization analysis of the diffracted beam.

XMaS: The army knife of SR x-ray techniques



SCATTERING:

SAXS/GISAXS
WAXS/GIWAXS

X-ray Reflectivity

Resonant Magnetic Reflectivity

DIFFRACTION:

Single crystals REXS, RMXS, RSM

Surface X-Ray Diffraction

SPECTROSCOPY:

XANES

EXAFS

X-ray Fluorescence



TECHNIQUES

Scattering:

(Surface) X-ray diffraction

GI-SAXS/SAXS

GI-WAXS/WAXS

X-ray reflectivity

Resonant magnetic reflectivity

Powder diffraction

Single crystals REXS, RMXS, RSM

Spectroscopy:

XANES, EXAFS

XRF, TXRF, GI-XRF, μ -XRF map

Individually or in combination

DIFFRACTOMETER MOUNTABLE SAMPLE ENVIRONMENTS

Solar chamber

Humidity cell

Linkam cell

Gas flow cell

Phase retarders (2.4 – 13.5 keV)

Polarisation analysis

In-vacuum electromagnet (± 0.1 T)

Remanence-free magnet (± 2 mT)

Superconducting magnet (± 4 T)

Electric field (up to 10 kV/mm)

Cryostats (1.8 K to 700 K)

Furnace (upon request; up to 1000 K)

Vacuum/He spectroscopy chamber

Ex-situ, in-situ or operando

APPLICATIONS

In-situ electrochemistry

Battery and Energy Materials, surface science

Operando heterogeneous catalysis

Multi-probe, furnace, gas flow, mass flow

Photovoltaic materials

Perovskites, organic solar cells, photonic materials

Soft matter

Liquid crystals, polymers, membranes

Magnetic Materials

Spintronics, AFM, DMI, magnetic multilayers

Multiferroics

Ferroelectric, piezoelectric materials

Health Care

Human enamel, crocodile teeth, tooth filling, biomaterials, tissue engineering

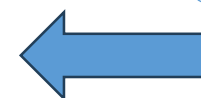

6-circle diffractometer

- PSIC geometry (4S + 2D)
- Fully refurbished
- Non-magnetic
- Double 2Θ arm
- Energy: 2.035 keV to over 47 keV
- Temperature: 1.8 K to 700 K
- Magnetic field: from ± 0.1 T to ± 4 T
- Voltage: up to ± 10 kV
- Phase-retarder for manipulation of the incident polarisation
- Polarisation analysis of the diffracted beam
- Expensive sample holder for some (SAXS/WAXS/XAS) experiments

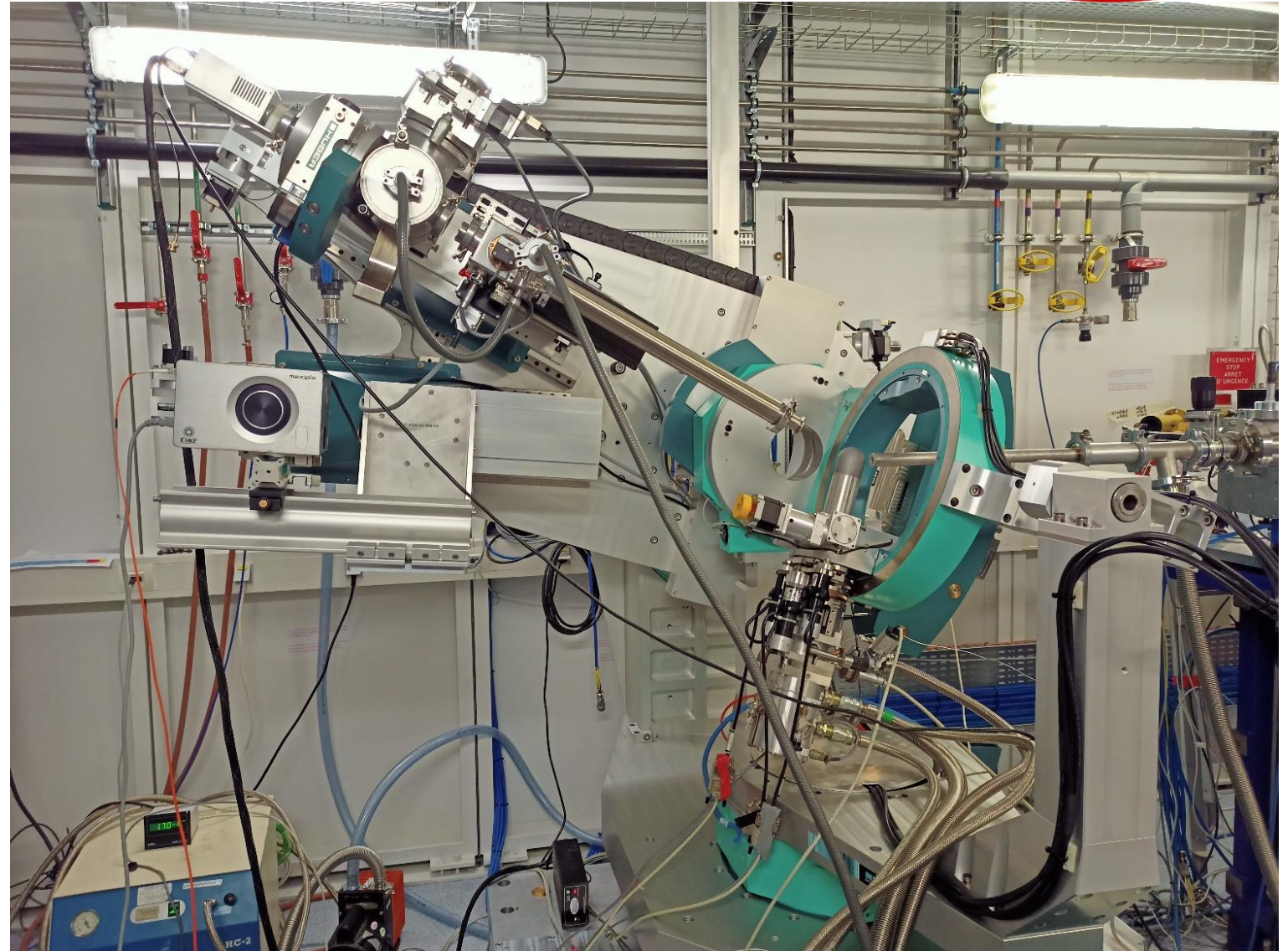

Wide suite of detectors



0D: ion chambers, APD, Vortex EX60 SDD, Ketek 150 mm² SDD, Vortex EX60 2 mm thick SDD, Vortex ME4 SDD and Mirion ME7 Ge.

2D: Pilatus3 300k, Pilatus3 1M, Maxipix 2x2, Lambda 750k CdTe and MAR165 CCD.

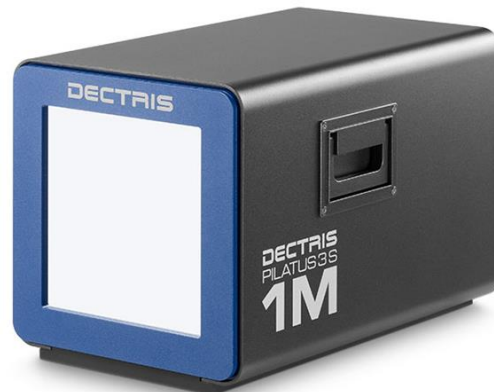

Sample environment

- 1.8 K to 700 K closed-cycled cryostat;
- Compatible with magnetic and/or electric field;
- Ball chamber for tender energy x-ray experiments;
- Electro-chemical cell;
- GIWAXS chamber for energy materials;
- Linkam cell;
- ...

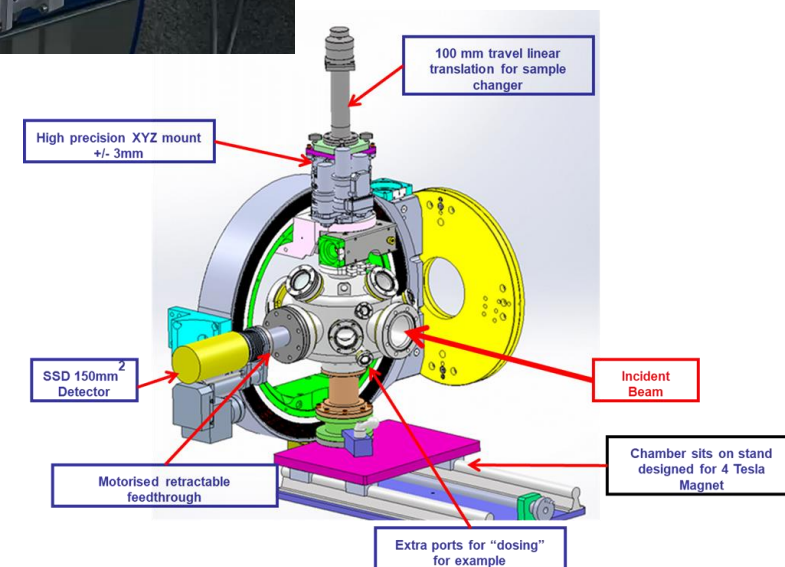
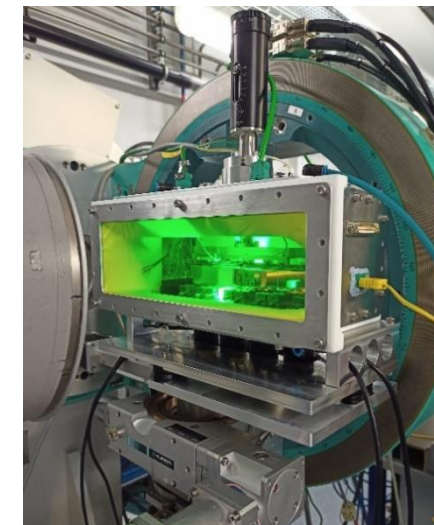

Sample environment



Magnetic field from ± 0.1 T to ± 4 T.

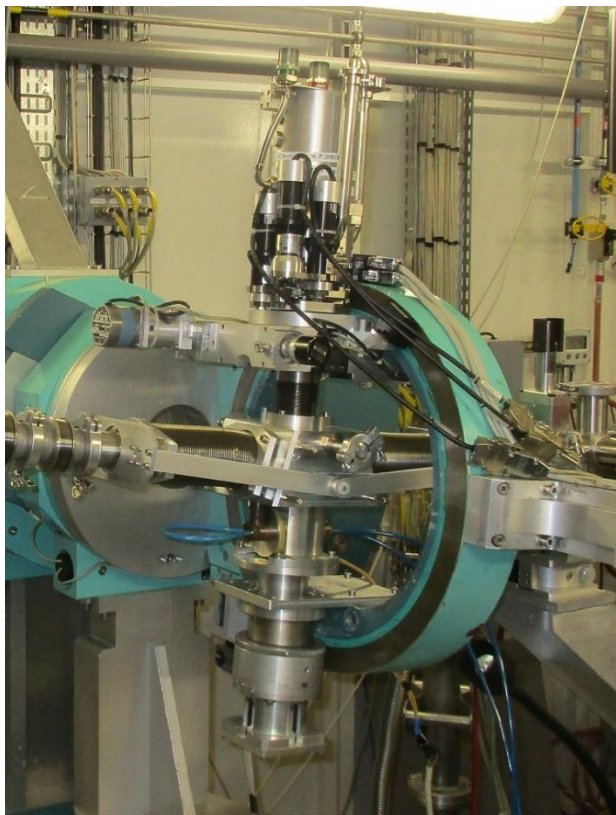

± 0.1 T in-vacuum magnet

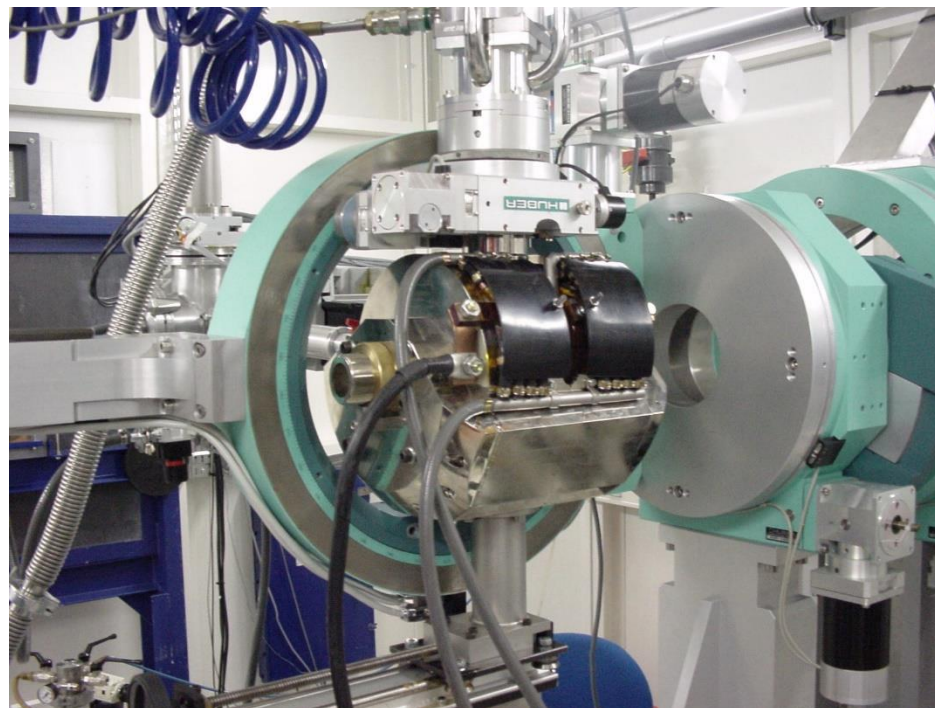

± 1 T electromagnet

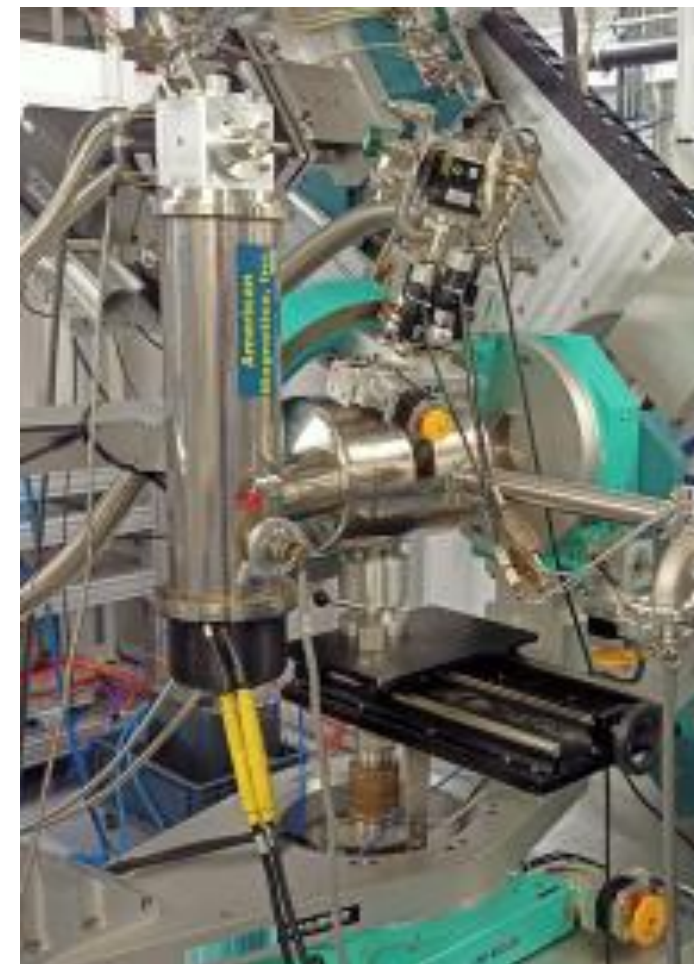

± 4 T superconducting magnet

Simultaneous measurements



Schematic setup of the XMaaS P-E loop system.

Vecchini C, Thompson P *et al.*,
 “Simultaneous dynamic electrical and structural measurements of functional materials”,
 Rev. Sci. Instrum. 2015, 86, 103901.

Chapman JBJ *et al.*,
 “Low temperature ferroelectric behavior in morphotropic $Pb(Zr_{1-x}Ti_x)O_3$ ”,
 J. Am. Ceram. Soc. 2018, 101, 874-882.

Finkel P, Thompson P *et al.*,
 “Simultaneous Large Optical and Piezoelectric Effects Induced by Domain Reconfiguration Related to Ferroelectric Phase Transition”,
 Adv. Mater. 2022, 2106827, 1-8.

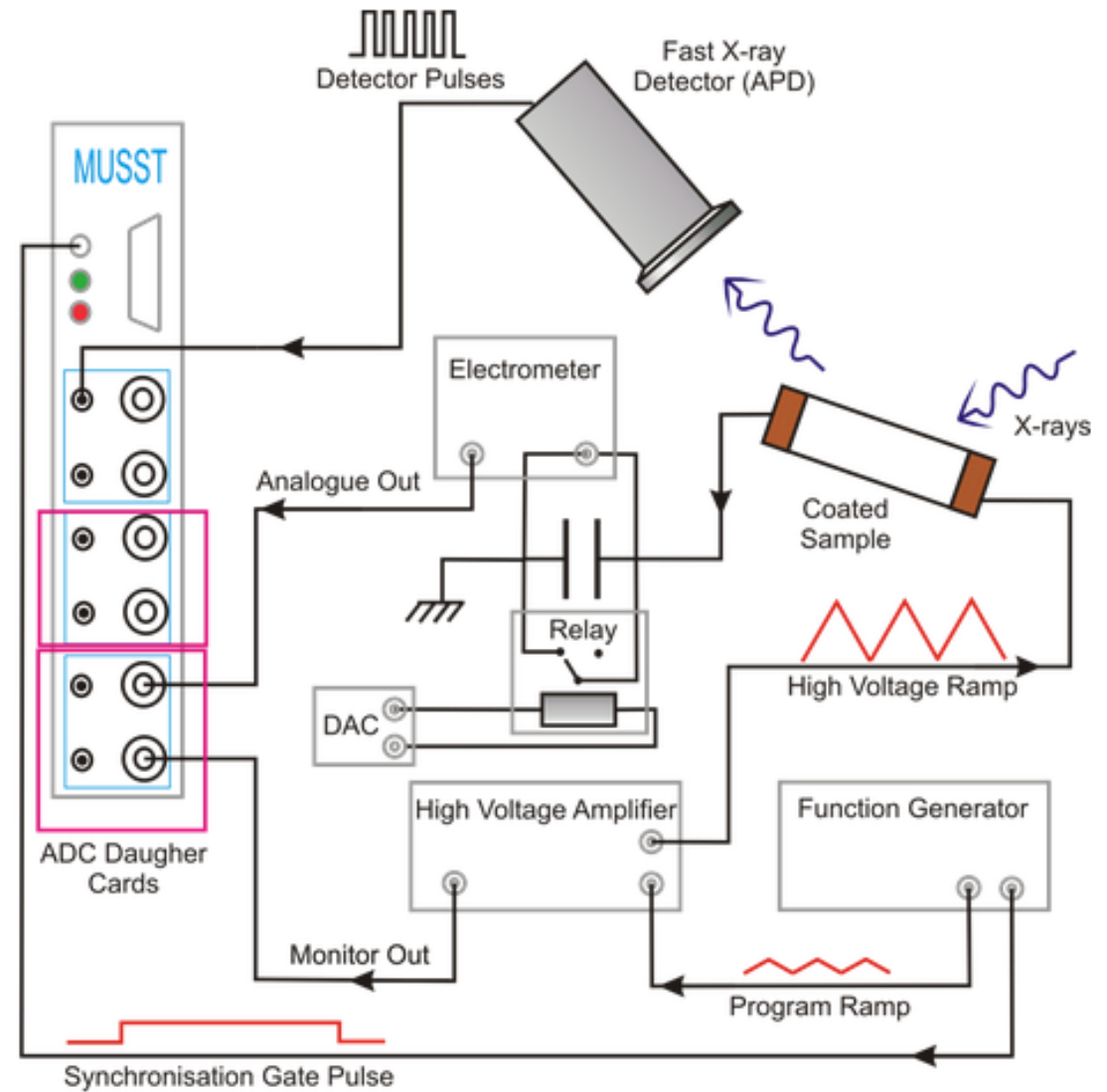
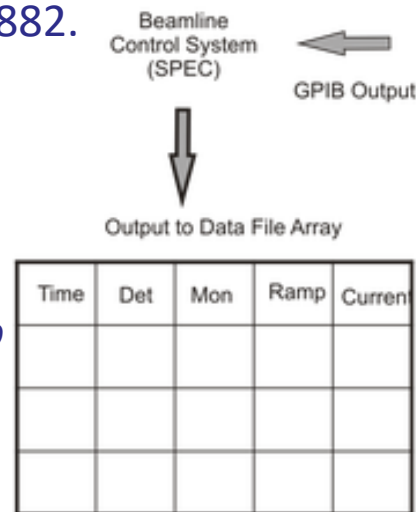

An evolving scientific landscape

Our strategy is to provide an easy-to-use facility to a broad user community and exploit sample environments for correlative characterisation. This allows us flexibility to address the latest research challenges.

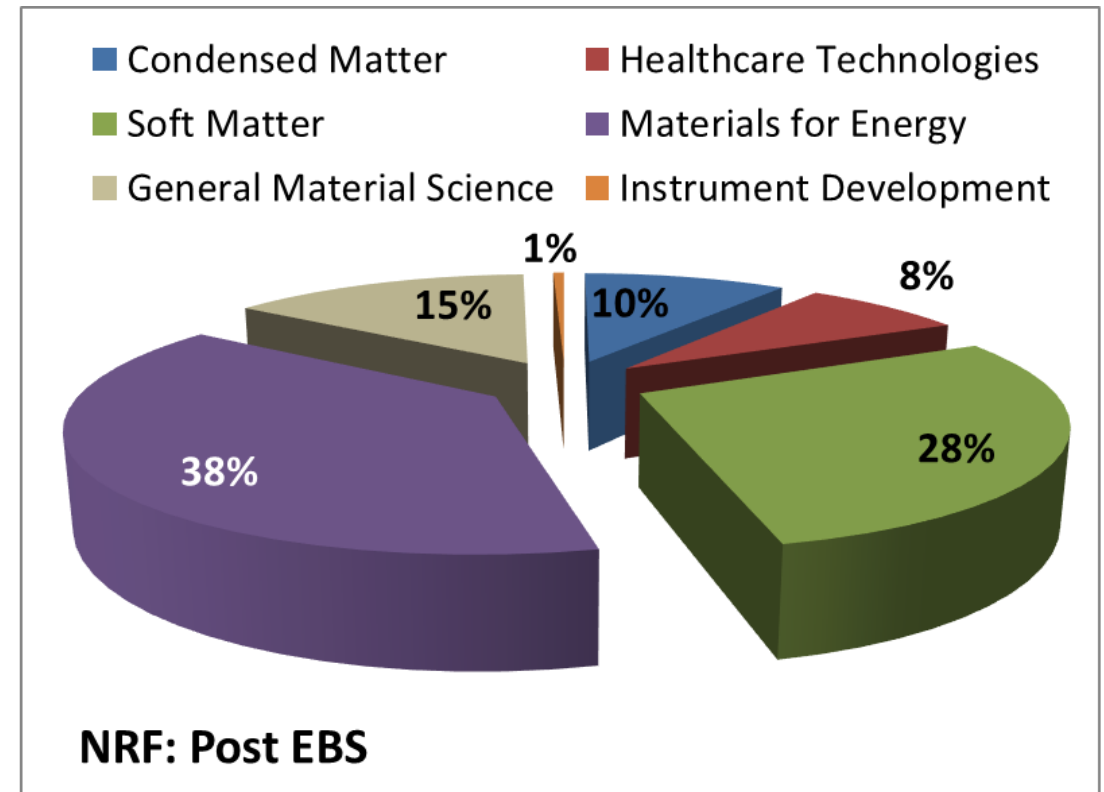
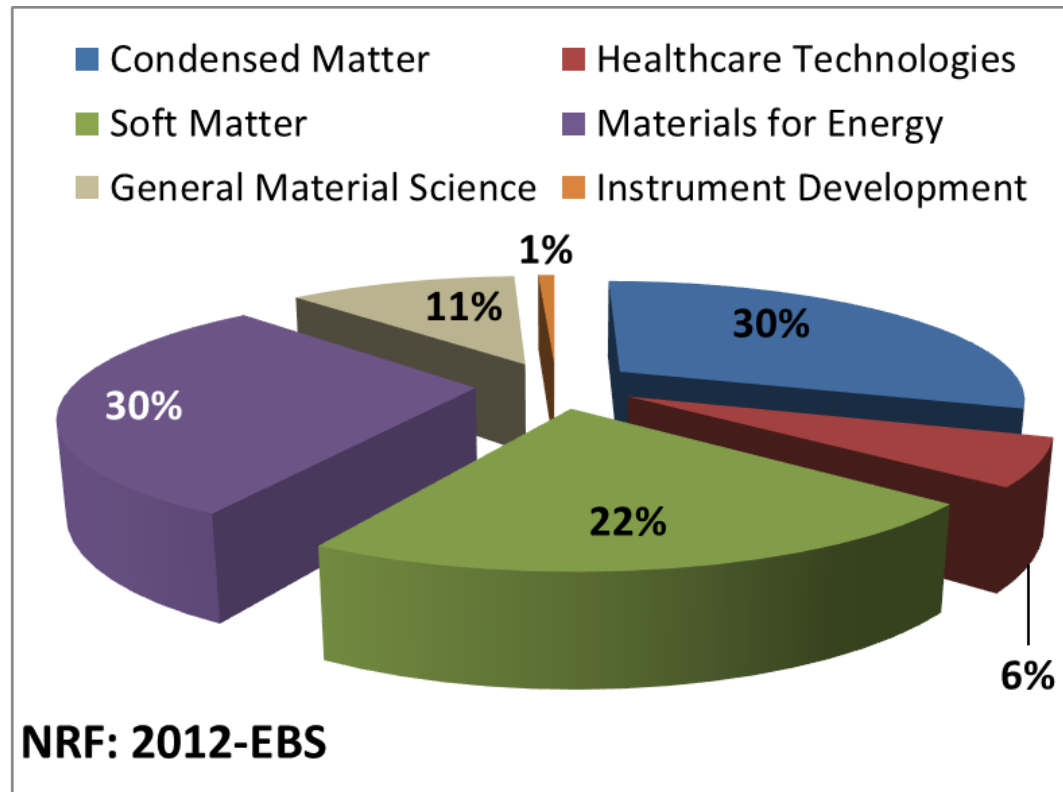

Science highlights

Simultaneous GI-WAXS and current-voltage measurements during *in situ* annealing of perovskite photovoltaics.

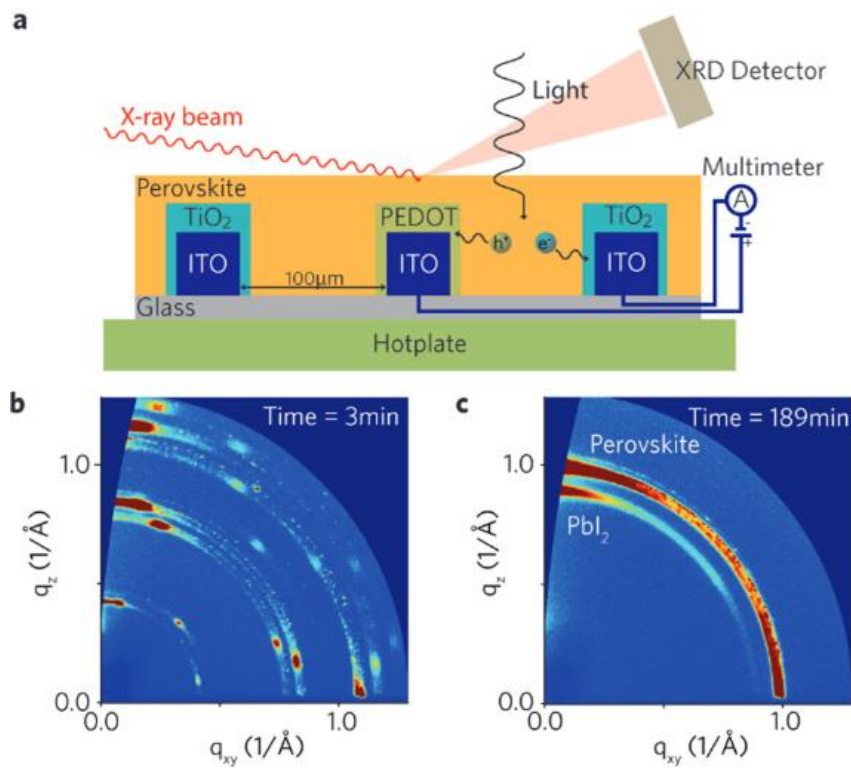

Alsari M, Lilliu S *et al.*, Energy Environ. Sci. 2018, 11, 383.

Formation of PdN_x structures in the selective oxidation of NH₃. XANES operando study at the Pd L₃-edge (3173.3 eV).

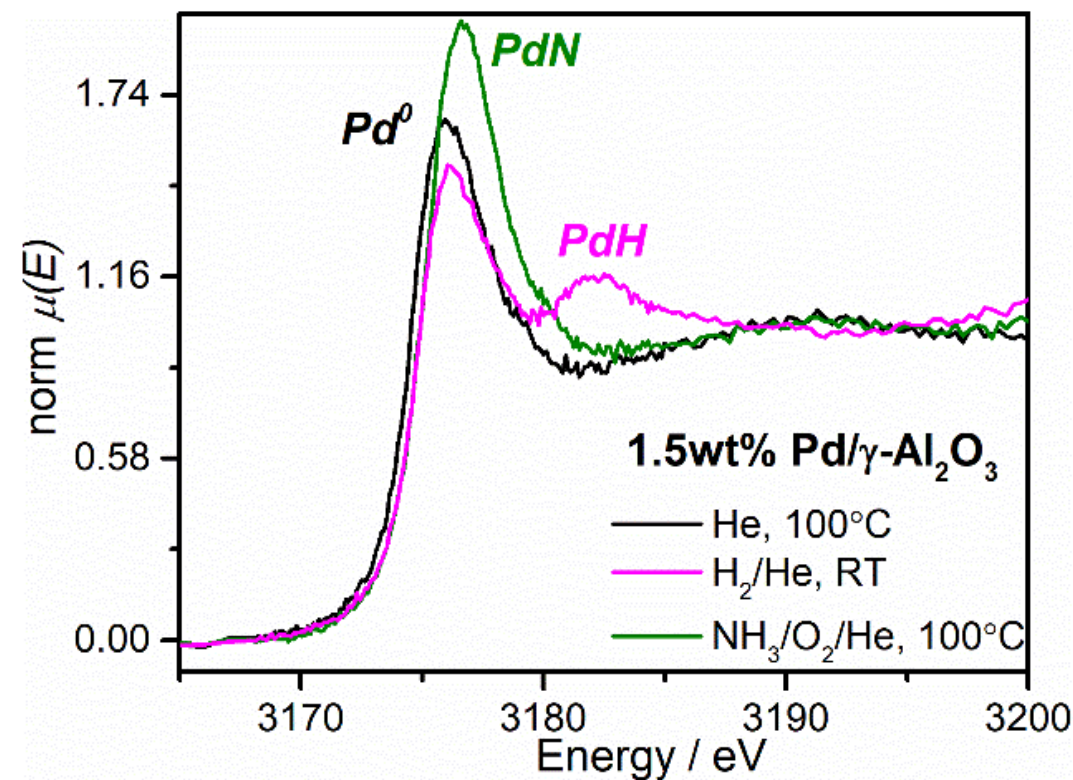

Dann E, Wells P *et al.*, Nat. Catal. 2019, 2, 157

Science highlights

Field-induced modulated states in ferromagnetic PrPtAl

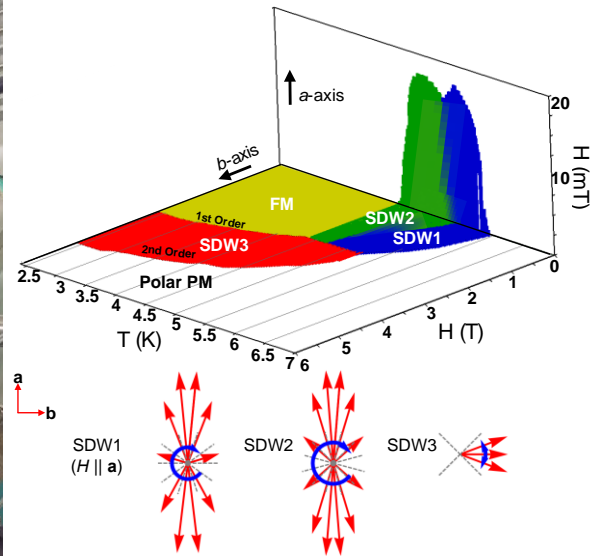

Abdul-Jabbar G, Huxley A *et al.*, Nat. Phys. 2015, 11, 321,

O'Neill C, Huxley A *et al.*, PRL 2021, 126, 197203.

Graphene surface structure in aqueous media

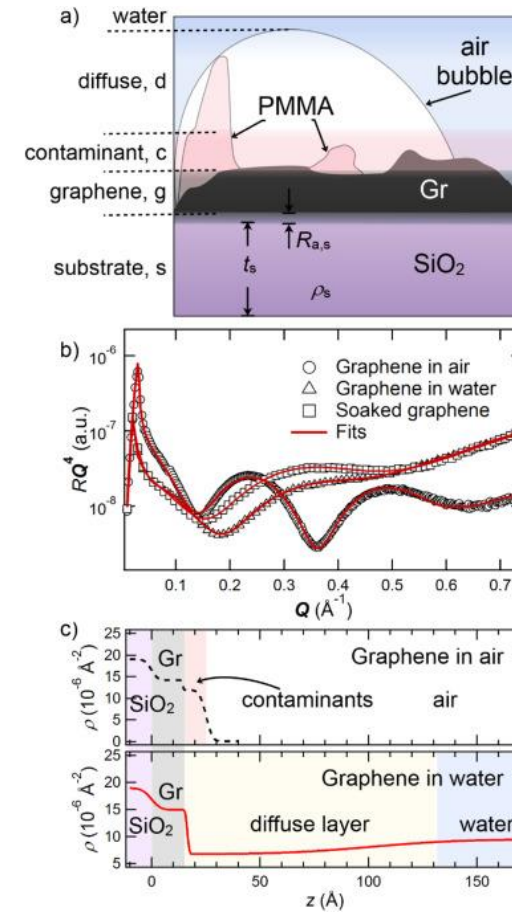

Zhou L, Briscoe W *et al.*, Carbon 2019, 143, 97.

Science highlights

Ba K-edge: 37.44 keV, done 9 – 11 Nov. 2024



PROFESSOR ADRIAN FINCH

The Professional pages of the Research Group of Adrian Finch

Home Adrian Finch Research Techniques Blog Personal Contact Communication

NOVEMBER 15, 2024 BY ADRIAN FINCH

XMaS Comes Early : Unlocking the Secrets of Barium in Corals using Synchrotron X-Rays

Adrian and past A-team member **Anouk Borst** recently completed an experiment on the XMaS beamline on the European Synchrotron to understand more about how barium fits into coral skeletons. This post is about the experiment and some of the burning questions that are driving this type of research.

The Geological Background to the Experiment

Climate change is a topic of global importance but people have only been recording systematically sea temperatures and circulation for less than a century. Hence, we do not know ocean conditions since

SEARCH

Search ...

SOCIAL

in

FOLLOW BLOG VIA EMAIL

Enter your email address to follow this blog and receive notifications of new posts by email.

Email Address

Follow

<https://adrianfinchcouk.wordpress.com/2024/11/15/xmas-comes-early-unlocking-the-secrets-of-barium-in-corals-using-synchrotron-x-rays/>



Anouk Borst's Post



Anouk Borst
Geologist | Senior Researcher at the Royal Museum for Central Africa (50%) | Assistant Prof...
3d · Edited

And now for something completely different: Corals.

Last weekend, **Adrian Finch** and I spent 3 successful days on the XMaS beamline (BM28) at the **ESRF - The European Synchrotron** in Grenoble. With the help of beamline scientist Laurence Bouchenoire, we measured the first Barium K-edge X-ray absorption spectroscopy data on carbonates and sulphates.

The goal was to determine Barium coordination state in corals (fossil, modern and cultured corals, from the lab of @NickyAllison in St Andrews) because Ba is used as a proxy for terrestrial run-off in (paleo)climate studies. Since the K-edge of Barium is at 37.4 keV you need a synchrotron & beamline set-up that allows measurements at a high energy range.

<https://lnkd.in/eRTmNAgD>

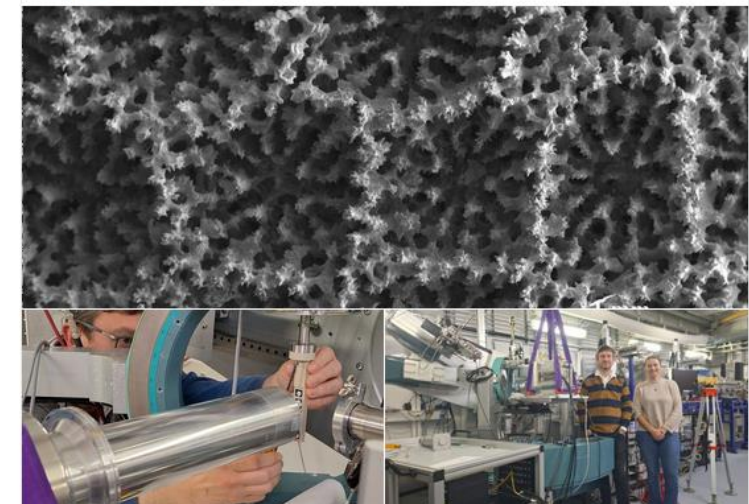

https://www.linkedin.com/posts/anoukborst_and-now-for-something-completely-different-activity-7262853887903035392-iyGK?utm_source=share&utm_medium=member_desktop



2,831 followers
243 Posts
View Profile

Explore topic

- Sales
- Marketing
- IT Services
- Business Administ
- HR Management
- Engineering
- Soft Skills
- See All

The sinews of war

A continually evolving user community, new techniques and upgrades in detectors and sample environments keep the facility at the forefront of materials science research.

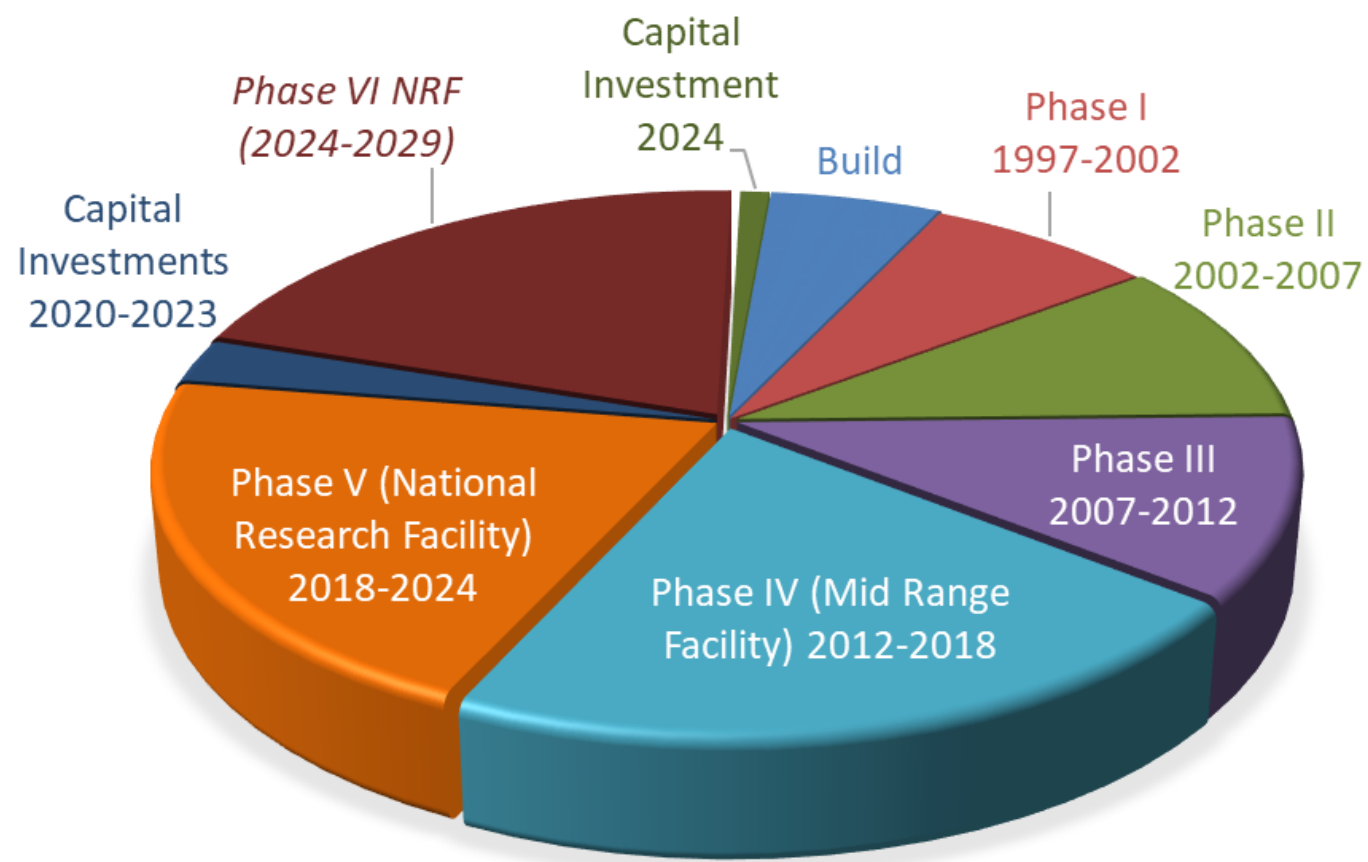

Currently funded until January 2029.

Additional funds through EPSRC Unmet Capital calls.

Total investment: £34.4M over 34 years, i.e. ~£1 M or < 2 cents per UK citizens per annum.



What does make *XMaS* unique?

Its staff. We never say: “No! It is not possible!”

Its energy range, from P *K*-edge at 2.1455 keV to Sm *K*-edge at 46.834 keV;

Its versatility. We change technique(s) and configuration almost every week;

Its suite of equipment (sample environment, detectors, ...);

Its offline facilities, with a Cu K_{α} x-ray laboratory μ -source and a sample characterization laboratory;

What does make *XMaS* unique?

Its staff. We never say: “No! It is not possible!”

Its energy range, from P K -edge at 2.1455 keV to Sm K -edge at 46.834 keV;

Its versatility. We change technique(s) and configuration almost every week;

Its suite of equipment (sample environment, detectors, ...);

Its offline facilities, with a Cu K_{α} x-ray laboratory μ -source and a sample characterization laboratory;

A little UK village in central Europe!



Trombinoscope



Local team:



Past staff:



UK directorate:



UK support:



www.xmas.ac.uk



That's all Folks!

Thank you!

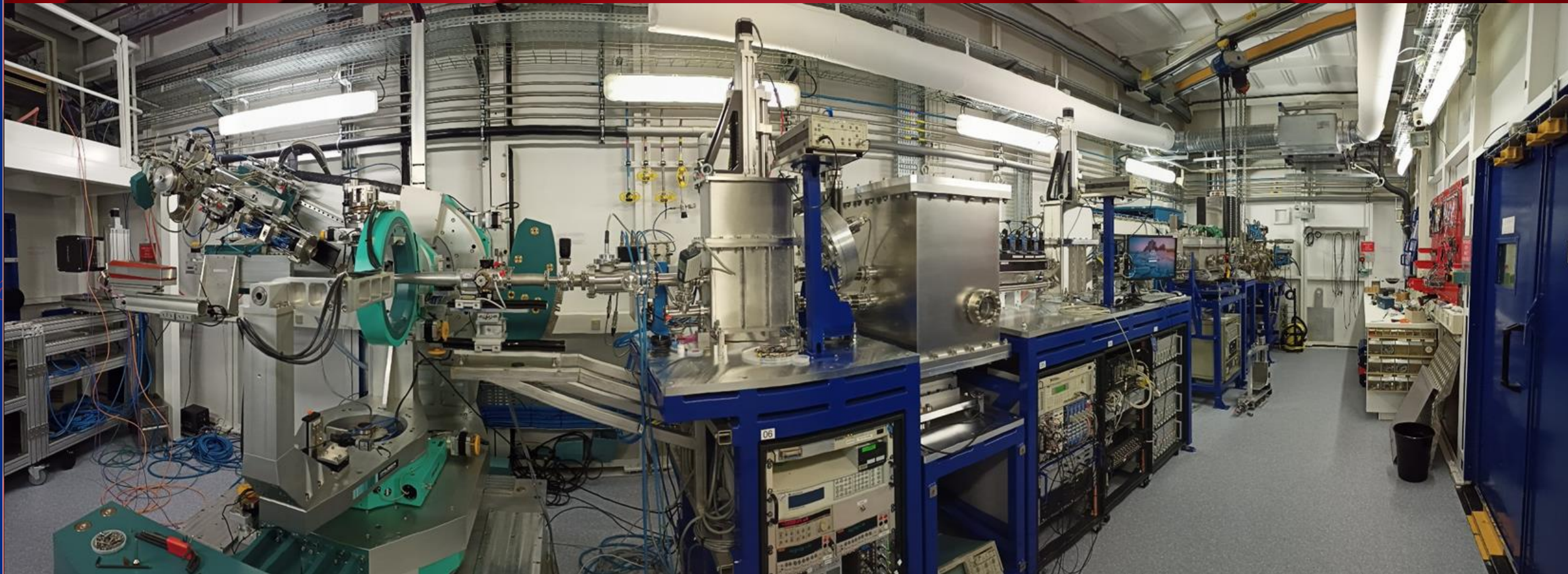

www.xmas.ac.uk